

OS2 Hardware User Manual

For Rev C OS2 Sensors

Ouster

Dec 01, 2020

Contents

1	Safety and Safe Use	3
1.1	Safety & Legal Notices	3
1.2	Proper Assembly, Maintenance and Safe Use	5
2	OS2 Overview	7
3	OS2 Product Models	8
4	Mechanical Interface	9
4.1	Included Components	9
4.2	Mounting Guidelines	10
4.3	Thermal Requirements	11
5	Electrical Interface	12
5.1	Interface Box	12
5.2	Direct Cable Connection and Pinout	13
6	Digital IO	14
6.1	SYNC_PULSE_IN	14
6.2	MULTIPURPOSE_IO (M_IO)	15
7	OS2 CAD files	17

1 Safety and Safe Use

1.1 Safety & Legal Notices

The OS2-128, OS2-64, and OS2-32 have been evaluated to be **Class 1 laser products** per **60825-1: 2014 (Ed. 3)** and operate in the 865nm band.



L'OS2-128, l'OS2-64, et l'OS2-32 répondent aux critères des **produits laser de classe 1**, selon la norme **IEC 60825-1: 2014 (3ème édition)** et émettent dans le domaine de l'infrarouge, à une longueur d'onde de 865nm environ.

FDA 21CFR1040 Notice: OS2-128, OS2-64, and OS2-32 comply with FDA performance standards for laser products except for deviations pursuant to Laser Notice No. 56, dated January 19, 2018.

Notice FDA 21CFR1040: L'OS2-128, l'OS2-64, et l'OS2-32 sont conformes aux exigences de performances établies par la FDA pour les produits laser, à l'exception des écarts en application de l'avis n°56, daté du 19 janvier 2018.



The following symbols appear on the product label and in the manual and have the following meaning.

-  This symbol indicates that the sensor emits laser radiation.
-  This symbol indicates the presence of a hot surface that may cause skin burn.

CAUTIONS:

- The OS2 is a hermetically sealed unit, and is non user-serviceable.
- Use of controls, or adjustments, or performance of procedures other than those specified herein, may result in hazardous radiation exposure.

- Your use of the OS2 is subject to the Terms of Sale that you signed with Ouster or your distributor/integrator. Included in these terms is the prohibition on:
 - Removing or otherwise opening the sensor housing
 - Inspecting the internals of the sensor
 - Reverse-engineering any part of the sensor
 - Permitting any third party to do any of the foregoing
- Operating the sensor without either the attached mount with which the sensor is shipped, or attaching the sensor to a surface of appropriate thermal capacity runs the risk of having the sensor overheat under certain circumstances.
- This product emits Class 1 invisible laser radiation. The entire window is considered to be the laser aperture. While Class 1 lasers are considered to be “eye safe”, avoid prolonged direct viewing of the laser and do not use optical instruments to view the laser.
- When operated in an ambient temperature $>40\text{ }^{\circ}\text{C}$, the metallic surfaces of the sensor may be hot enough to potentially cause skin burn. Avoid skin contact with the sensor’s base, lid and heatsink when the sensor is operated under these conditions.

PRECAUTIONS:

- L’OS2 est une unité hermétiquement scellée, qui ne peut être entretenue ou modifiée par l’utilisateur.
- L’utilisation de commandes, de réglages, ou l’exécution de procédures autres que celles spécifiées dans le présent document peuvent entraîner des rayonnements laser dangereux.
- L’utilisation de l’OS2 est soumise aux conditions de vente signées avec Ouster ou le distributeur/intégrateur, incluant l’interdiction de:
 - Retirer ou ouvrir de quelque façon le boîtier du capteur
 - Analyser les composants internes du capteur
 - Pratiquer la rétro-ingénierie de toute ou partie du capteur
 - Autoriser une tierce personne à mener les actions listées ci-dessus
- Ce produit émet un rayonnement laser invisible de classe 1. L’ouverture de sortie du laser est constituée par la fenêtre du capteur dans sa totalité. Même si les lasers de classe 1 ne sont pas considérés comme dangereux pour les yeux, ne regardez pas directement le rayonnement laser de façon prolongée et n’utilisez pas d’instruments optiques pour observer le rayonnement laser.
- Lors d’une utilisation à température ambiante supérieure à 40°C , la surface métallique du capteur peut présenter des risques de brûlures pour la peau. Dans ces conditions, il est important d’éviter tout contact avec la partie supérieure, la base ou le dissipateur thermique du capteur.

Equipment Label: Note that the equipment label, which includes model and serial number and notice that the unit is a Class 1 Laser Product, is affixed to the underside of the Sensor Enclosure Base itself. It is only visible after the attached mount with which the Sensor is shipped, is removed. Please refer

to location details in the [Mechanical Interface](#) section.

L'étiquette de l'équipement, comprenant le modèle, le numéro de série, et la classification du produit laser (ici, classe 1), est apposée au dessous de la base du boîtier du capteur. Il n'est visible qu'après avoir retiré le diffuseur de chaleur avec lequel le capteur est expédié. L'emplacement est décrit avec précision dans la section «[Mechanical Interface](#)».

Electromagnetic Compatibility: The OS2 is an FCC 47 CFR 15 Subpart B device. This device complies with part 15 of the FCC Rules. Operation is subject to the following conditions: (1) This device may not cause harmful interference, and (2) this device must accept any interference received, including interference that may cause undesired operation.

“Ouster” and “OS2” are both registered trademarks of Ouster, Inc. They may not be used without express permission from Ouster, Inc.

If you have any questions about the above points, contact us at legal@ouster.io.

1.2 Proper Assembly, Maintenance and Safe Use

The OS2 may be easily setup by mounting to the base to a mounting with the correct mounting hole pattern, and following the interconnection instructions delineated in [Mounting Guidelines](#). Any mounting orientation is acceptable. Each sensor is shipped attached to a mount for test or normal use specified operating temperature range, but the sensor may be mounted directly to any appropriate mount with Thermal Capacity appropriate for the application of the user. Please contact Ouster for assistance with approving the use of user specific mounting arrangements.

Any attempt to utilize the sensor outside the Environmental parameters delineated in the OS2 data sheet may result in voiding of the warranty.

When power is applied, the sensor powers up and commences boot-up with the laser disabled. The bootup sequence is approximately 60s in duration, after which the internal sensor optics subassembly commences spinning, and the laser is activated, and the unit operates in the default 1024 x 10 Hz mode. When the sensor is running, and the laser is operating, a faint red flickering light may be seen behind the optical window. Note that the OS2 utilizes an 865nm infrared laser that is only dimly discernable to the naked eye, while transmitting a laser eye- safe fundamental signal in the 865nm IR band. While the sensor is fully Class 1 eye safe, Ouster strongly recommends against peering into the optical window at close range while the sensor is operating. The OS2 is a hermetically sealed unit, and is not user-serviceable. Any attempt to unseal the enclosure has the potential to expose the operator to hazardous laser radiation.

Ouster sensors are equipped with a multi-layer series of internal safety interlocks to ensure compliance to Class 1 Laser Eye Safe limits.

The Sensor user interface may be used configure the sensor to a number of combinations of scan rates and resolutions other than the default values of 1024 x 10 Hz resolution. In all available combinations, the unit has been evaluated by an NRTL to remain within the classification of a Class 1 Laser Device as per IEC 60825-1:2014 (Ed. 3).

Assemblage correct et utilisation sûre

L'OS2 s'installe facilement en fixant la base sur un support percé de trous concordants, et en suivant les instructions d'interconnexion décrites dans la section «*Mounting Guidelines*». Toute orientation de montage est acceptable. Chaque capteur est expédié équipé d'un dissipateur de chaleur, utilisable en phase de test et en conditions normales. Néanmoins tout autre support présentant une capacité thermique appropriée pour l'application de l'utilisateur peut être utilisé. Veuillez contacter Ouster dans le cas où un montage spécifique à votre application serait nécessaire.

Toute tentative d'utilisation du capteur en dehors des paramètres environnementaux définis dans la fiche technique de l'OS2 peut entraîner l'annulation de la garantie.

Lorsque le capteur est sous tension, celui-ci démarre et commence son initialisation avec le laser désactivé. Le temps de démarrage est d'environ 60s, après quoi le sous-système optique entre en rotation et le laser est activé, le capteur opère alors dans son mode par défaut de 1024 x 10 Hz. Lorsque le capteur est en marche et que le laser est active, on peut apercevoir une faible lumière rouge vacillante derrière la vitre teintée. L'OS2 utilise une longueur d'ondes infra-rouge de 865nm nm à peine perceptible pour l'œil humain, et le rayonnement laser IR émis est sans danger pour les yeux. Cependant, bien que les rayonnements laser de classe 1 soient sans danger dans des conditions raisonnablement prévisibles, Ouster recommande fortement de ne pas regarder fixement la vitre teintée pendant que le capteur est en marche. L'OS2 est une unité hermétiquement scellée, qui ne peut pas être entretenue, modifiée ou réparée par l'utilisateur. Toute tentative d'ouverture du boîtier a pour risque d'exposer l'opérateur à un rayonnement laser dangereux.

L'OS2 est une unité hermétiquement scellée, qui ne peut pas être entretenue, modifiée ou réparée. Toute tentative d'ouverture du boîtier a pour risque d'exposer l'opérateur à un rayonnement laser dangereux.

Les capteurs Ouster sont équipés d'une série de dispositifs de sécurité à plusieurs niveaux, de façon à assurer en toutes circonstances le respect des limites d'irradiance correspondant aux rayonnements lasers de classe 1, sans danger pour les yeux.

L'interface utilisateur du logiciel du capteur peut être utilisée pour configurer le capteur selon un certain nombre de combinaisons de vitesses de balayage et de résolutions autres que les valeurs utilisées par défaut, respectivement de 1024 x 10 Hz.

2 OS2 Overview

The OS2 offers an industry-leading combination of range, resolution, price, performance, reliability, size, weight, and power. It is designed for indoor/outdoor all-weather environments. As the smallest and lightest long-range high-resolution lidar on the market, the OS2 can be directly integrated into vehicles, robots, and drones.

The OS2 family of sensors consist of three models, the OS2-128, OS2-64, and OS2-32, with differing resolution, but of identical mechanical dimensions.

HIGHLIGHTS

- Fixed resolution per frame operating mode
- Camera-grade intensity, near-infrared, and range data
- Multi-sensor crosstalk immunity
- Simultaneous and co-calibrated 2D and 3D output
- Industry leading intrinsic calibration
- Example client code available

For the purposes of this document, the term "OS2" refers to the family of sensors, and only where there is a difference in performance will each model be referred to by its specific model designation.

3 OS2 Product Models

The OS2 is available with 128, 64, or 32 beams of vertical resolution and with Uniform, Gradient, Above Horizon, or Below Horizon beam spacing options. Product specs and more information on these configurations can be found on the [OS2 product page](#).

4 Mechanical Interface

4.1 Included Components

The OS2 is shipped with the following items:

- OS2-128, OS2-64, or OS2-32
- Sensor to interface box cable/connector
- Interface Box and 24V AC/DC power supply (2 meters)
- RJ45 cable (1 meter)
- Optional: Heat sink

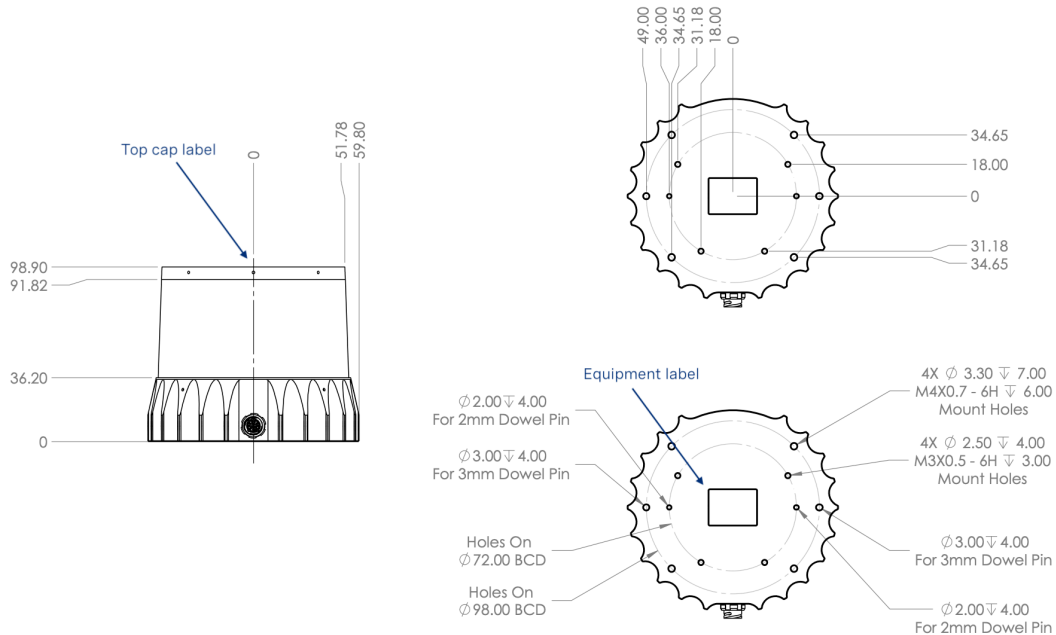

Downloadable CAD files for the OS2 can be found online at www.ouster.com/lidar-product-details

Warning: Water ingress protection: The sensor ingress protection rating is only valid if the I/O cable is plugged into the panel mount connector on the base of the sensor, and the locking collet rotated past the detent click to the properly locked condition i.e past the détente position. The cable and plug are an element of the sensor ingress protection system. Without this the ingress protection rating may be compromised. Bending the cable at a sharp angle directly after egress from the plug over mold should also be avoided. Sharp bends and high axial stresses on the ca-

ble immediately adjacent to the plug over mold may create a moisture ingress path into the the connector. Please note the cable minimum bend radius requirements below:

I/O Cable type	O.D.	Cable Minimum Bend Radius	
		Fixed Bend	Flexing Bend
Ouster Thick Cable	10.5mm	79mm (7.5*OD)	158mm (15*OD)
Ouster Thin Cable (Standard)	8mm	50mm (5*OD)	80mm (10*OD)

4.2 Mounting Guidelines

Our sensors ship with modular mounting options. Proper mounting will ensure optimal sensor performance, reducing noise from vibration and providing efficient heat dissipation.

- Mount to a material with high thermal conductivity. The following are recommended aluminum alloys and their thermal conductivity:
 - 1) 6061: 167 W/m-K
 - 2) 7075: 130 W/m-K
 - 3) 2024: 121 W/m-K
- Ensure interfaces are clean and free from debris
- Torque bolts appropriately for the mount material and bolts
- Use TIM (Thermal Interface Material) for any irregular or unmachined surfaces
- Do not overconstrain the sensor if mounting to both the top and the bottom
- Use a thermally conductive pad to ensure good conductivity while not overconstraining.
- Ensure your implementation maintains the base and top of the sensor at no greater than 25°C above ambient with an ambient less than 50°C
- The shape of any heatsink should maximize the surface area for free and forced convection while being thick enough to allow the heat to conduct through the material

If you have questions about your specific mounting situation please contact the Ouster at support@ouster.io.

4.3 Thermal Requirements

Thermal requirements specific to Rev C OS2 are listed below.

Table 4.1: Thermal requirements for OS2

	Chassis Temp (°C)	Convective Air Temp with No Accessories (°C)
Max Temp before Shot Limiting	67	55
Temp of Shot Limiting Saturation	73	61
Max Temp Before Sensor May Shut Off	73	61

5 Electrical Interface

5.1 Interface Box

The Interface Box that accompanies the OS2 is designed to allow the sensor to be operated for test and evaluation purposes. It terminates the interface cable from the sensor, allows it to be powered up and provides access to the sensor gigabit Ethernet Interface via a standard RJ45 connector. DC Power to the sensor is provided to the Interface Box by the accompanying 24V DC supply.

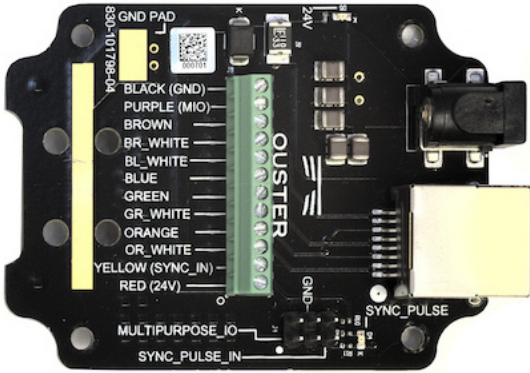
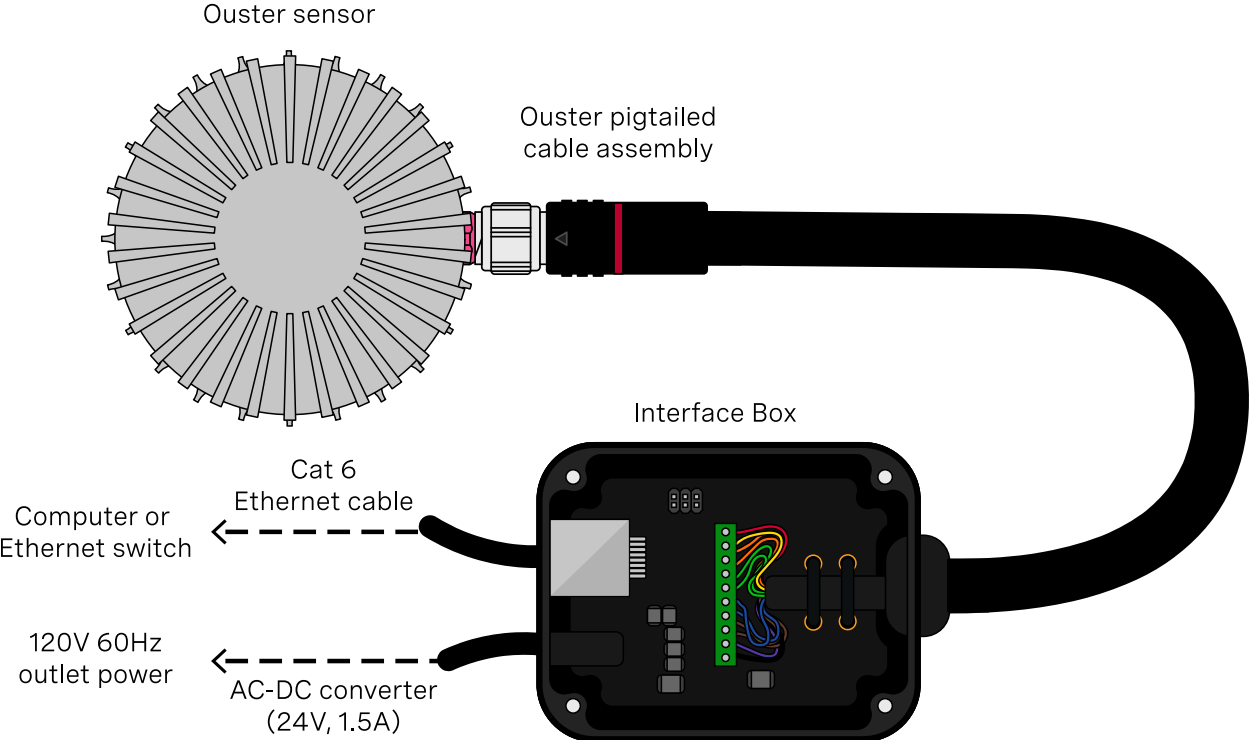

5.2 Direct Cable Connection and Pinout

The OS2 can be operated without the use of an Interface Box.

Warning: Ouster is not responsible for any errors in wiring as a result of bypassing the Interface Box and this activity may result in a voiding of your warranty if it results in damage to the sensor. The following guidelines for direct cable connection assume use of the Ouster-provided 24V 1.5A power supply. Ouster cannot be held responsible for damage to the device if alternate is used

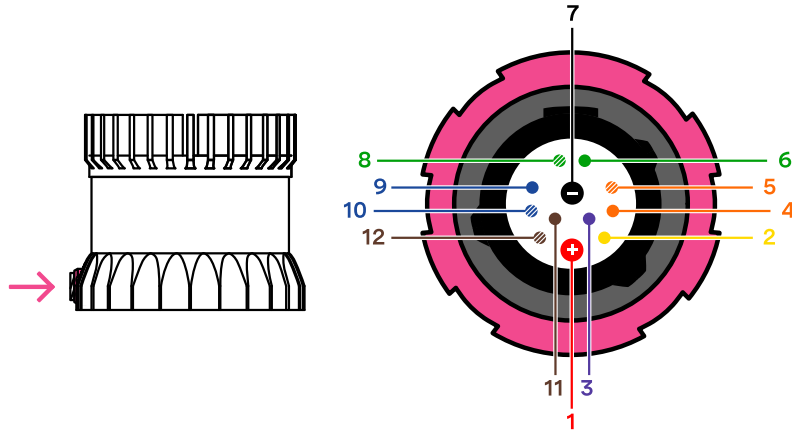

Figure 5.1: cable pinout of on-sensor receptacle

Table 5.1: Ouster Cable Pinout: Connector, Sensor P/Ns: 840_101855, 840_102144, 840_102145, 840_102146

Net Name	Pin Number	Wire	Twisted With
MULTIPURPOSE_IO	3	Purple, 26 AWG	N/A
SYNC_PULSE_IN	2	Yellow, 26 AWG	N/A
VCC_24	1	Red, 22 AWG	N/A
GROUND	7	Black, 22 AWG	N/A
TRP_1_P (Ethernet)	5	White/Orange, 26 AWG	Orange
TRP_1_N (Ethernet)	4	Orange, 26 AWG	White/Orange
TRP_2_P (Ethernet)	8	White/Green, 26 AWG	Green
TRP_2_N (Ethernet)	6	Green, 26 AWG	White/Green
TRP_3_P (Ethernet)	9	Blue, 26 AWG	White/Blue
TRP_3_N (Ethernet)	10	White/Blue, 26 AWG	Blue
TRP_4_P (Ethernet)	12	White/Brown, 26 AWG	Brown
TRP_4_N (Ethernet)	11	Brown, 26 AWG	White/Brown

6 Digital IO

6.1 SYNC_PULSE_IN

SYNC_PULSE_IN is a dedicated input channel that is accessible within the Interface Box Jumper J4. This channel expects an input pulse sequence which can be used for time synchronization. See the Software User Manual for more information on configuring this input. Any references to pulse polarity in this document references the signal polarity on the **SYNC_PULSE_IN** pin of the sensor. This input channel is protected by an optoisolator which will draw 10mA at full turn on.

Table 6.1: SYNC_PULSE_IN Interface Requirements

Parameter	Min Voltage	Max Voltage	Min Driver Current
LOGIC LOW	0 V	1 V	N/A
LOGIC HIGH	3.3 V	15 V	5 mA

SYNC_PULSE_IN Interface Requirements were tested with 2 m cable Interface Box connection at 2 MHz.

- When GPIO has 5 mA drive strength minimum, GPIO can be directly connected to the **SYNC_PULSE_IN** pin of the interface box header. This is the most common case and has been tested to work on common Arduino microcontroller series. Typical common logic levels of 3.3 V, 5 V GPIO of microcontrollers can produce drive strength of 5 mA min (Arduino, MSP430, etc.).

Requires 5 mA min drive strength to turn on optoisolator LED

3.3 V ~ 24 V GPIO PIN above 5 mA drive strength

OS1 SYNC_IN (header pin of the interface box)

Most GPIO microcontroller falls into this case (ARDUINO UNO, MSP430, etc.)

- If the 5 mA drive strength minimum cannot be met, a buffer circuit is required to drive **SYNC_PULSE_IN**. Example circuits are provided for common 3.3 V and 5 V logic.

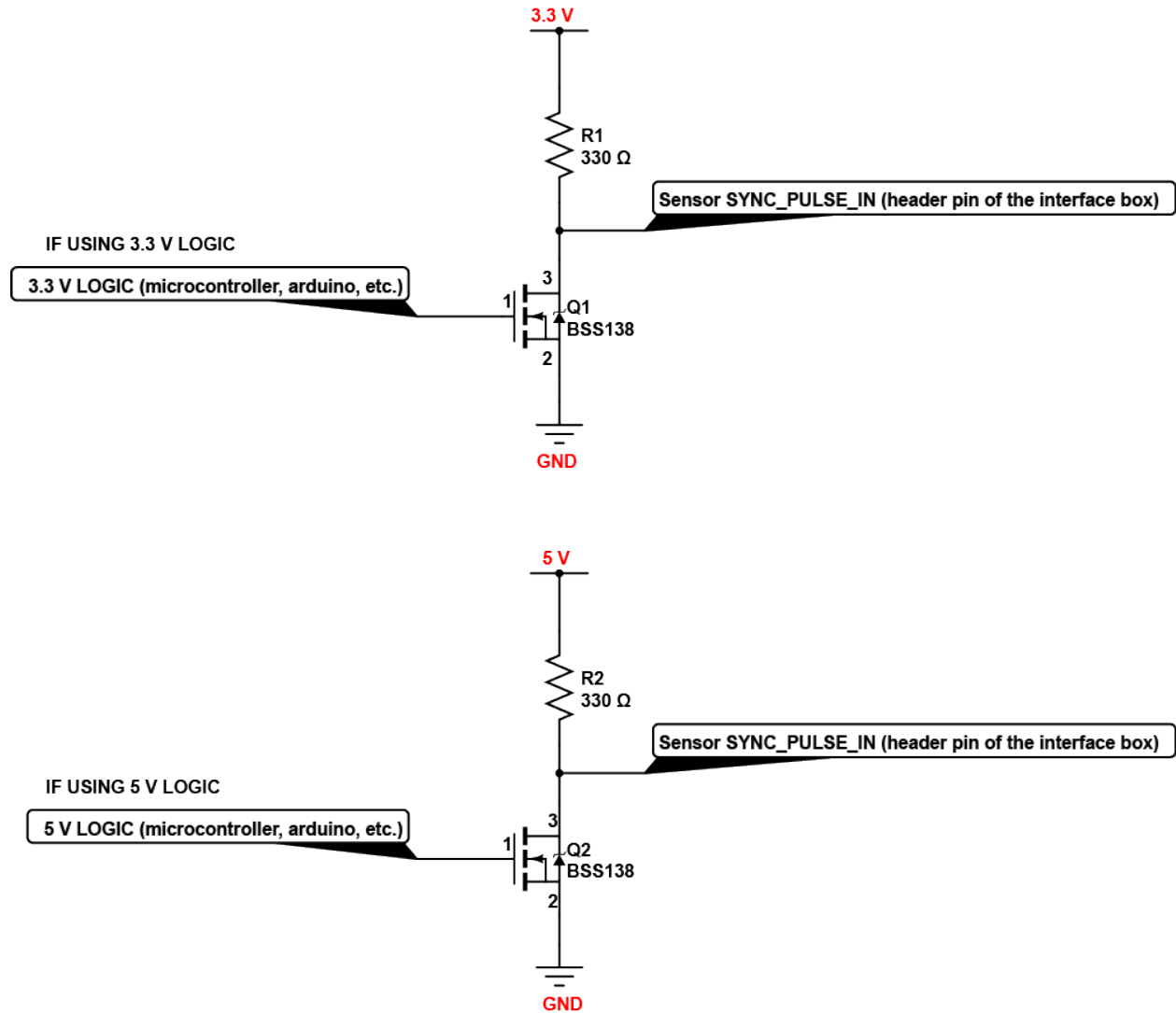

6.2 MULTIPURPOSE_IO (M_IO)

MULTIPURPOSE_IO (M_IO) is a configurable input or output channel accessible within the Interface Box Jumper J4 connected to the MULTIPURPOSE_IO pin of the Interface Box. Detailed information on how to configure this channel using the sensor TCP interface can be found in the API Guide. By default this channel is disabled.

When this channel is configured as an **OUTPUT**, the **M_IO** sends a pulse sequence that can be used for timesynchronization or event triggering outside the sensor. For a full description of output pulse triggering options, see the Software User Manual section. This output is an optoisolated open collector circuit, relying on an externally provided pull-up resistor. This resistor is not provided as part of the Interface Box.

Table6.2: MULTIPURPOSE_IO - OUTPUT Interface Requirements

Parameter	Min	Max
Pull Up Voltage	N/A	15 V
Sinking Current	N/A	25 mA

When this channel is configured as an **INPUT**, the **M_IO** can accept a standard NMEA \$GPRMC UART message. These messages are a common way for GPS systems to share timestamp information in UTC time format. More information on this packet structure and supported baud rates can be found in the Time Synchronization section of the Software User Manual.

Table6.3: MULTIPURPOSE_IO - INPUT Interface Requirements

Parameter	Min Voltage	Max Voltage	Min Driver Current
LOGIC LOW	0 V	1 V	N/A
LOGIC HIGH	1.7 V	15 V	10 mA

Above are tested with 2 m cable interface box connection at 2 MHz.

7 OS2 CAD files

All the most up-to-date CAD files of our products can be found on our [Lidar Product Details](#) page.