

OS0

Ultra-Wide View High-Resolution Imaging Lidar

FIRMWARE VERSION: 3.x

HARDWARE VERSION: REV7

SUMMARY

The short range OS0 delivers 35 m range on a dark 10% target and an ultra-wide 90° vertical field-of-view delivering an industry-leading combination of price, performance, reliability, size, weight, and power. The OS0 is designed for all-weather environments and due to its small size, can be easily integrated into autonomous vehicles. heavy

HIGHLIGHTS

- 100% increase in range with the new L3 Chip
- Dual Return mode
- Calibrated reflectivity
- Fixed resolution per frame
- Camera-grade near-infrared and signal data
- Multi-sensor crosstalk suppression
- Open source ROS and C++ drivers
- Ouster SDK for software development

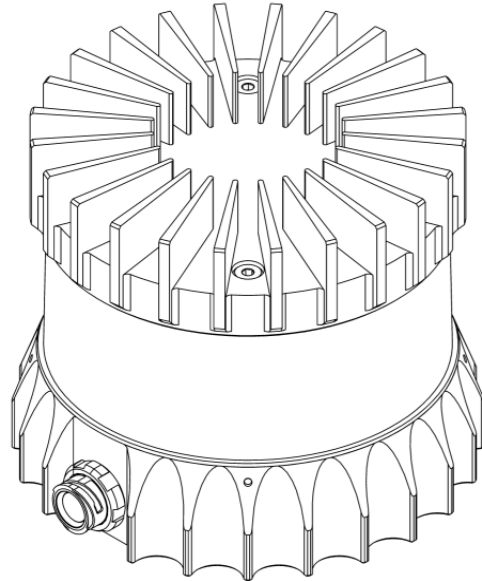

OPTICAL PERFORMANCE

Range (80% Lambertian reflectivity, 1024 @ 10 Hz mode)	75 m @ 100 klx sunlight, >90% detection probability
Range (10% Lambertian reflectivity, 1024 @ 10 Hz mode)	35 m @ 100 klx sunlight, >90% detection probability
Minimum Range	0.5 m default, 0.0 m optional in FW 3.1
Vertical Resolution	32, 64, or 128 channels
Horizontal Resolution	512, 1024, or 2048 (configurable)
Rotation Rate	10 or 20 Hz (configurable)
Field of View	Vertical: 90° (+45° to -45°) Horizontal: 360°
Angular Sampling Accuracy	Vertical: ±0.01° / Horizontal: ±0.01°
False Positive Rate	1/10,000
Range Resolution	0.1 cm Note: For <i>Low Data Rate Profile</i> the Range Resolution = 0.8cm
# of Returns	2 (strongest, second strongest)

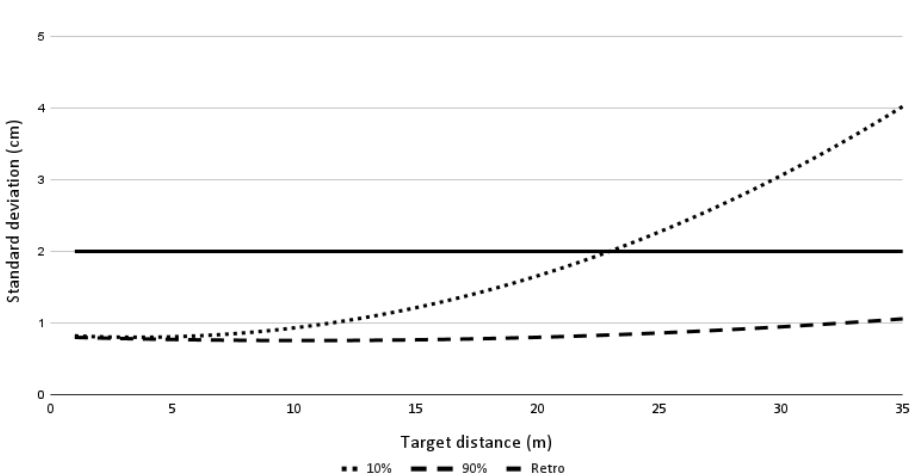
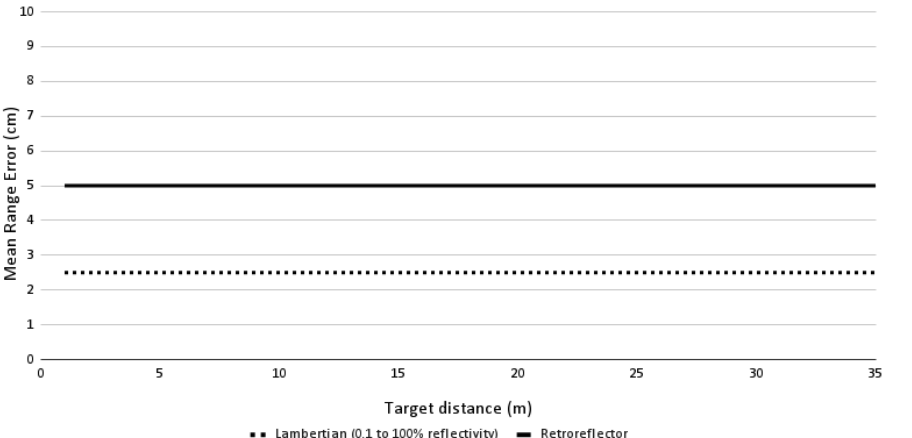
<p>Range Precision (Typical on Lambertian and Retroreflective targets beyond 1m, 1024 @ 10 Hz mode, 1 standard deviation)</p> <p>Note: "Precision is calculated based on the standard deviation of 100 measurements on a static target at a given range"</p>	<p>Min: ± 0.8 cm, Max: ± 4 cm</p>  <table border="1"> <caption>Standard deviation (cm) vs Target distance (m)</caption> <thead> <tr> <th>Target distance (m)</th> <th>10% (dotted)</th> <th>90% (dashed)</th> <th>Retro (solid)</th> </tr> </thead> <tbody> <tr><td>0</td><td>0.8</td><td>0.8</td><td>2.0</td></tr> <tr><td>5</td><td>0.9</td><td>0.8</td><td>2.0</td></tr> <tr><td>10</td><td>1.1</td><td>0.8</td><td>2.0</td></tr> <tr><td>15</td><td>1.5</td><td>0.8</td><td>2.0</td></tr> <tr><td>20</td><td>2.1</td><td>0.9</td><td>2.0</td></tr> <tr><td>25</td><td>2.8</td><td>0.9</td><td>2.0</td></tr> <tr><td>30</td><td>3.6</td><td>1.0</td><td>2.0</td></tr> <tr><td>35</td><td>4.5</td><td>1.1</td><td>2.0</td></tr> </tbody> </table>	Target distance (m)	10% (dotted)	90% (dashed)	Retro (solid)	0	0.8	0.8	2.0	5	0.9	0.8	2.0	10	1.1	0.8	2.0	15	1.5	0.8	2.0	20	2.1	0.9	2.0	25	2.8	0.9	2.0	30	3.6	1.0	2.0	35	4.5	1.1	2.0
Target distance (m)	10% (dotted)	90% (dashed)	Retro (solid)																																		
0	0.8	0.8	2.0																																		
5	0.9	0.8	2.0																																		
10	1.1	0.8	2.0																																		
15	1.5	0.8	2.0																																		
20	2.1	0.9	2.0																																		
25	2.8	0.9	2.0																																		
30	3.6	1.0	2.0																																		
35	4.5	1.1	2.0																																		
<p>Range Accuracy (Typical on Lambertian and Retroreflective targets beyond 1m, 1024 @ 10 Hz mode)</p> <p>Note: "Accuracy is calculated based on the error between the mean of 100 measurements on a static target at a given range and the true range"</p>	 <table border="1"> <caption>Mean Range Error (cm) vs Target distance (m)</caption> <thead> <tr> <th>Target distance (m)</th> <th>Lambertian (0.1 to 100% reflectivity) (dotted)</th> <th>Retroreflector (solid)</th> </tr> </thead> <tbody> <tr><td>0</td><td>2.5</td><td>5.0</td></tr> <tr><td>5</td><td>2.5</td><td>5.0</td></tr> <tr><td>10</td><td>2.5</td><td>5.0</td></tr> <tr><td>15</td><td>2.5</td><td>5.0</td></tr> <tr><td>20</td><td>2.5</td><td>5.0</td></tr> <tr><td>25</td><td>2.5</td><td>5.0</td></tr> <tr><td>30</td><td>2.5</td><td>5.0</td></tr> <tr><td>35</td><td>2.5</td><td>5.0</td></tr> </tbody> </table>	Target distance (m)	Lambertian (0.1 to 100% reflectivity) (dotted)	Retroreflector (solid)	0	2.5	5.0	5	2.5	5.0	10	2.5	5.0	15	2.5	5.0	20	2.5	5.0	25	2.5	5.0	30	2.5	5.0	35	2.5	5.0									
Target distance (m)	Lambertian (0.1 to 100% reflectivity) (dotted)	Retroreflector (solid)																																			
0	2.5	5.0																																			
5	2.5	5.0																																			
10	2.5	5.0																																			
15	2.5	5.0																																			
20	2.5	5.0																																			
25	2.5	5.0																																			
30	2.5	5.0																																			
35	2.5	5.0																																			

LASER

Laser Product Class	Class 1 eye-safe per IEC/EN 60825-1: 2014
Laser Wavelength	865 nm
Beam Diameter Exiting Sensor	5 mm
Beam Divergence	0.35° (FWHM)

LIDAR OUTPUT

Connection	UDP over gigabit Ethernet
Points Per Second	1,310,720 (32 channel) 2,621,440 (64 channel) 5,242,880 (128 channel)
Data Rate (Megabits Per Second) (Legacy Mode) 2048x10	66 Mbps (32 channel) 129 Mbps (64 channel) 254 Mbps (128 channel)
Data Rate (Megabits per second) (Dual Return Profile at highest resolution 2048x10)	up to 86.55 Mbps (32 channel) up to 170.43 Mbps (64 channel) up to 338.20 Mbps (128 channel)

Data Rate (Megabits per second) (Low Data Rate Profile)	up to 23.6 Mbps (32 channel) up to 44.6 Mbps (64 channel) up to 86.6 Mbps (128 channel)
Data Rate (Megabits per second) (Single Return Profile)	up to 65.6 Mbps (32 channel) up to 128.5 Mbps (64 channel) up to 254.3 Mbps (128 channel)
Data Per Point	Range, signal, reflectivity, near-infrared, channel, azimuth angle, timestamp
Timestamp Resolution	< 1 μ s
Data Latency	< 10 ms

IMU OUTPUT

Connection	UDP over 1000Base-T or 1000Base-T1
Samples Per Second	100
Data Per Sample	3 axis gyro, 3 axis accelerometer
Timestamp Resolution	< 1 μ s
Data Latency	< 10 ms
Additional Details	InvenSense IAM-20680HT; datasheet for more details: https://invensense.tdk.com/download-pdf/iam-20680ht-datasheet/

CONTROL INTERFACE

Connection	TCP and HTTP APIs
Time Synchronization	Input sources: <ul style="list-style-type: none"> • IEEE1588 Precision Time Protocol (PTP); Accuracy: <1 ms error • gPTP; Accuracy: <1 ms error • NMEA \$GPRMC UART message support • External PPS; Accuracy: <1 ms error • Internal 10 ppm drift clock; Accuracy: <20 ppm error Output sources: <ul style="list-style-type: none"> • Configurable 1 - 60 Hz output pulse
Lidar Operating Modes	Hardware-triggered angle firing (guaranteed fixed resolution per rotation): <ul style="list-style-type: none"> • x 512 @ 10 Hz or 20 Hz • x 1024 @ 10 Hz or 20 Hz • x 2048 @ 10 Hz
Additional Programmability	Multi-sensor Phase Lock Azimuth Masking Low-power Standby Mode Queryable intrinsic calibration information: <ul style="list-style-type: none"> • Beam angles • IMU pose correction matrix

MECHANICAL/ELECTRICAL

Power Consumption	14 - 20 W (22 W peak at startup, 28 W peak if operating at -40 °C) Note: Ouster recommends use of a power brick (no less than 30 W) if using in extreme outdoor conditions."
Connector	Proprietary pluggable connector (Power + data + DIO)

Operating Voltage	<ul style="list-style-type: none"> • Suitable for 12VDC and 24VDC Nominal systems. • Not suitable for 48V nominal battery based systems. • Under voltage conditions/alarms occur at 9.5VDC at connector. • Over voltage conditions/alarms occur at 51VDC at connector. • Overvoltage lockout onset at 58VDC ($\pm 1V$) at connector. • Overvoltage lockout release: 55VDC ($\pm 1V$) at connector.
Dimensions	Diameter: 87 mm (3.42 in) Height: <ul style="list-style-type: none"> • Without cap: 58.35 mm (2.3 in) • With thermal cap: 74.2 mm (2.9 in)
Weight	Without cap: 430 g (15.1 oz) With radial cap: 500 g (17.6 oz)
Mounting	Bottom: 4x M3 screws, 2x locating 2 mm pin holes Top: 4x M3 screws, 4x locating 2 mm pin holes, 1x M6 screw

OPERATIONAL

Operating Temperature	-40 °C to +60 °C (with mount) Between +53 °C and +60 °C, sensor automatically reduces range (max 20% range reduction)
Storage Temperature	-40 °C to +105 °C
Ingress Protection	IP68 (1m submersion for 1 hour, with I/O cable attached) IP69K (with I/O cable attached)
Shock	IEC 60068-2-27 (Amplitude: 100 g, Shape: 11 ms half-sine, 3 shocks x 6 directions)
Vibration	IEC 60068-2-64 (Amplitude: 3 G-rms, Shape: 10 - 1000 Hz, Mounting: sprung masses, 3 axes w/ 8 hr duration each)
Compliance	<p>For US</p> <p>Laser Safety:</p> <ul style="list-style-type: none"> • EN/IEC 60825-1:2014 Class 1 eye safe • FDA US 21CFR1040 Notice 56 Class 1 <p>Product Safety:</p> <ul style="list-style-type: none"> • UL 62368-1 • UL 60950-22 (outdoor use) • CSA-C22.2 No. 62368-1-19 • CSA-C22.2 No. 60950-22-07 (outdoor use) <p>EMC: FCC 47CFR Part 15, Subpart B, Class A</p> <p>For EU</p> <p>Laser Safety: EN/IEC 60825-1:2014 Class 1 eye safe</p> <p>Product Safety: EN/IEC 62368-1</p> <p>Note: Ouster UK (Ltd): 125 Princes Street, Edinburgh EH2 4AD, Scotland, United Kingdom Contact: Neil Calder, Phone Number: +44(0).131.563.9078</p> <p>EMC:</p> <ul style="list-style-type: none"> • EN 55032:2012/AC 2013; CISPR 32:2015 • EN 55024:2010; CISPR 24:2010 • EN 61000-3-2:2014 • EN 61000-3-3:2013



ACCESSORIES

Interface Box	Polycarb/FR4, 100 g, 75 mm x 50 mm x 25 mm (LxWxH), 2 m CAT6 cable, 24 V power adapter, 5 m sensor cable
Mount	Aluminum, 530 g, 110 mm x 110 mm x 20.5 mm (LxWxH), 4 x M8 thru holes

SOFTWARE

Sample Drivers	Ouster SDK, ROS, C++
----------------	----------------------

EXTERIOR DIMENSIONS

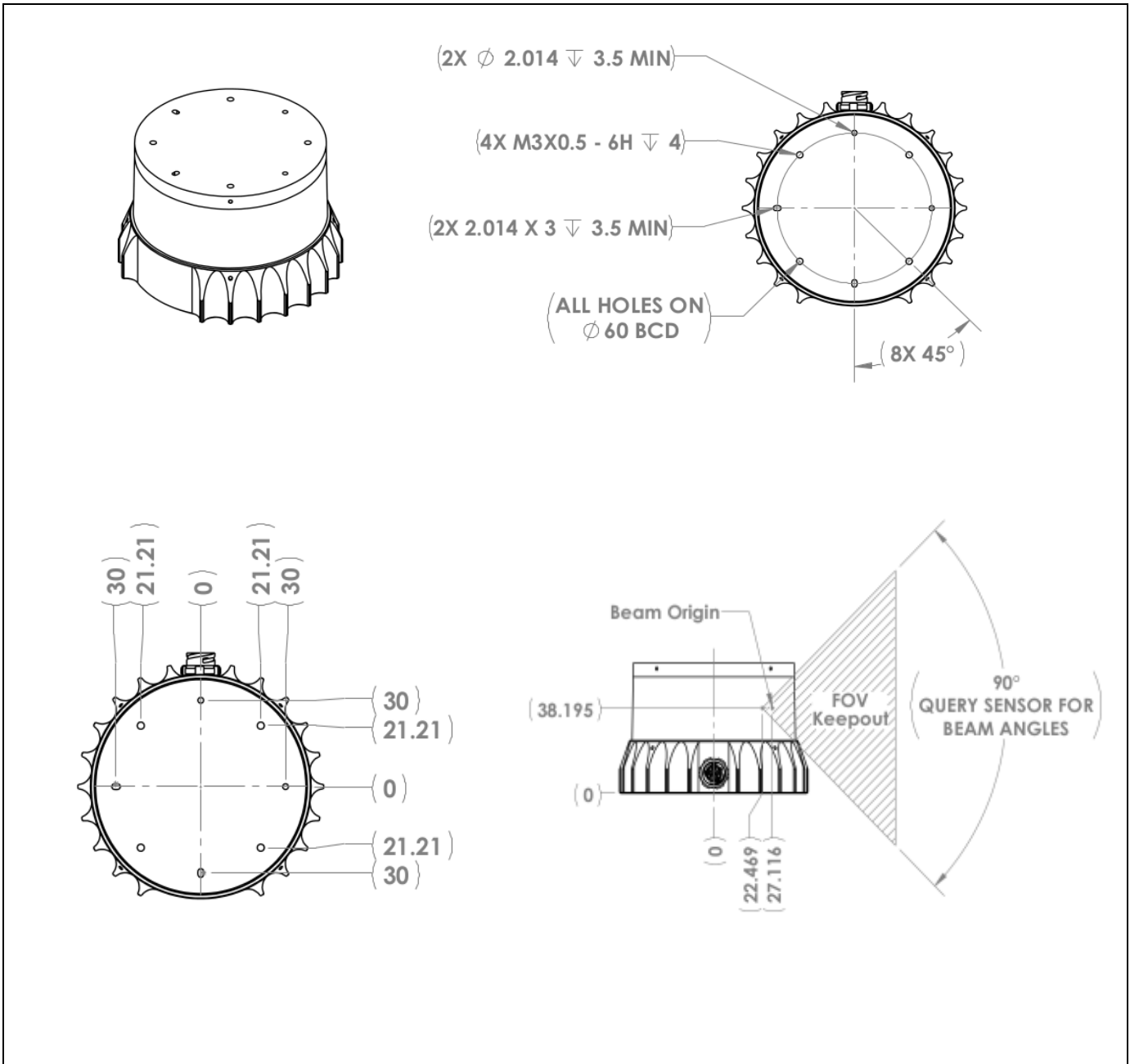

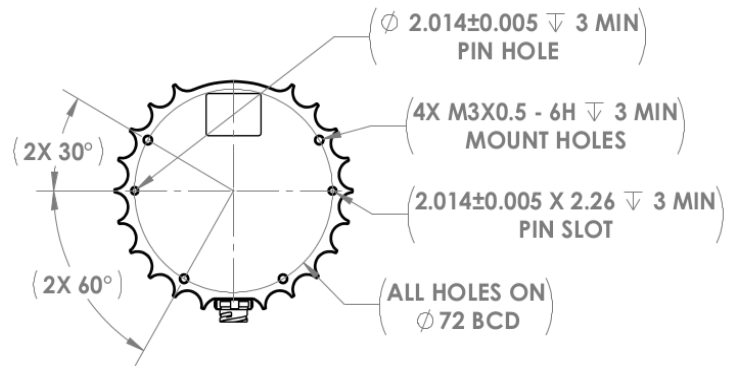
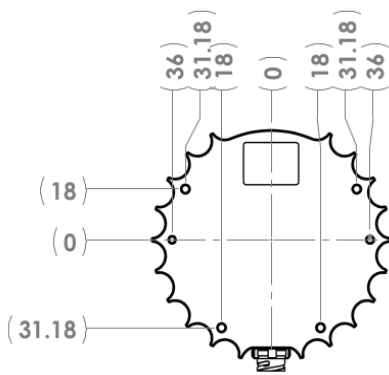
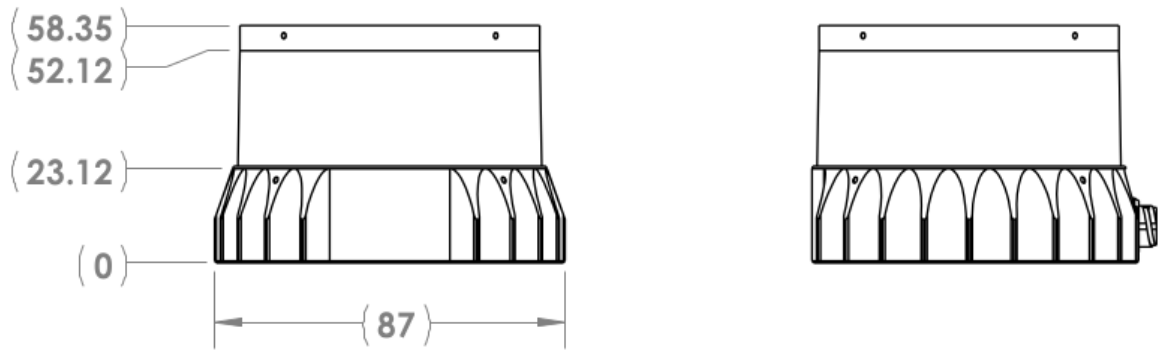

*Specifications are subject to change without notice.

WWW.OUSTER.COM

REV: 04/29/2024 • © 2024 Ouster, Inc. • All rights reserved