

Revision: 04/20/22

FIRMWARE VERSION: v2.3.x

HARDWARE VERSION: 840-102xxx-06 (Rev 06)

SUMMARY

The OS1 offers an industry-leading combination of price, performance, reliability, size, weight, and power. It is designed for indoor/outdoor all-weather environments and long lifetime. As the smallest high performance lidar on the market, the OS1 can be directly integrated into robots, drones, and fixed infrastructure.

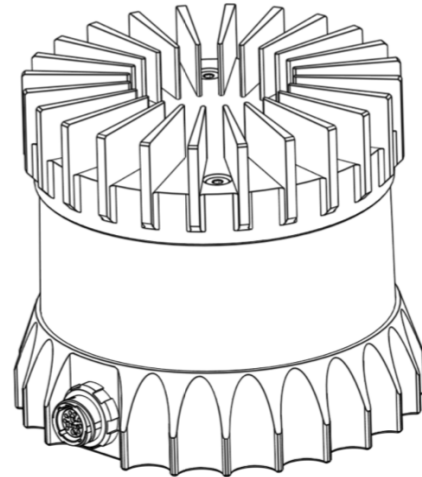

HIGHLIGHTS

- Fixed resolution per frame
- Camera-grade near-infrared and intensity data
- Multi-sensor crosstalk immunity
- Fixed intrinsic calibration
- Open source drivers
- 2x signal processing power and 2x data output per pixel with the new L2X Chip
- Introducing Dual Return Mode
- New UDP packet profiles `Single Return` and `Low Data Rate`

OPTICAL PERFORMANCE

Range (80% Lambertian reflectivity, 1024 @ 10 Hz mode)	100 m @ >90% detection probability, 100 klx sunlight 120 m @ >50% detection probability, 100 klx sunlight
Range (10% Lambertian reflectivity, 1024 @ 10 Hz mode)	45 m @ >90% detection probability, 100 klx sunlight 55 m @ >50% detection probability, 100 klx sunlight
Minimum Range	0.3 m for point cloud data
Range Accuracy	±3 cm for lambertian targets, ±10 cm for retroreflectors
Precision (10% Lambertian reflectivity, 1024 @ 10 Hz mode, 1 standard deviation)	0.3 - 1 m: ± 0.7 cm 1 - 20 m: ± 1 cm 20 - 50 m ± 2 cm >50 m: ± 5 cm
Range Resolution	0.1 cm Note: For <i>Low Data Rate Profile</i> the Range Resolution = 0.8cm
Vertical Resolution	32, 64, or 128 channels
Horizontal Resolution	512, 1024, or 2048 (configurable)
Field of View	Vertical: 45° (+22.5° to -22.5°) Horizontal: 360°
Angular Sampling Accuracy	Vertical: ±0.01° / Horizontal: ±0.01°
False Positive Rate	1/10,000
Rotation Rate	10 or 20 Hz (configurable)
# of Returns	2 (strongest, second strongest)

LASER

Laser Product Class	Class 1 eye-safe per IEC/EN 60825-1: 2014
Laser Wavelength	865 nm
Beam Diameter Exiting Sensor	9.5 mm
Beam Divergence	0.18° (FWHM)

LIDAR OUTPUT

Connection	UDP over gigabit Ethernet
Points Per Second	up to 655,360 (32 channel) up to 1,310,720 (64 channel) up to 2,621,440 (128 channel)
Data Rate (Megabits Per Second) (Legacy Mode)	up to 66.2 Mbps (32 channel) up to 129.1 Mbps (64 channel) up to 255 Mbps (128 channel)
Data Rate (Megabits per second) (Dual Return Profile) Not applicable for 1024x20 & 2048x10 Modes	up to 43.6 Mbps (32 channel) up to 85.6 Mbps (64 channel) up to 169.4 Mbps (128 channel)
Data Rate (Megabits per second) (Low Data Rate Profile)	up to 23.6 Mbps (32 channel) up to 44.6 Mbps (64 channel) up to 86.6 Mbps (128 channel)
Data Rate (Megabits per second) (Single Return Profile)	up to 65.6 Mbps (32 channel) up to 128.5 Mbps (64 channel) up to 254.3 Mbps (128 channel)
Data Per Point	Range, signal, reflectivity, near-infrared, channel, azimuth angle, timestamp
Timestamp Resolution	< 1 μ s
Data Latency	< 10 ms

IMU OUTPUT

Connection	UDP over gigabit Ethernet
Samples Per Second	100
Data Per Sample	3 axis gyro, 3 axis accelerometer
Timestamp Resolution	< 1 μ s
Data Latency	< 10 ms
Additional Details	InvenSense ICM-20948; datasheet for more details: https://www.invensense.com/products/motion-tracking/9-axis/icm-20948/

CONTROL INTERFACE

Connection	TCP and HTTP APIs
Time Synchronization	Input sources: <ul style="list-style-type: none">• IEEE1588 Precision Time Protocol (PTP); Accuracy: <1 ms error• gPTP; Accuracy: <1 ms error• NMEA \$GPRMC UART message support• External PPS; Accuracy: <1 ms error• Internal 10 ppm drift clock; Accuracy: <20 ppm error Output sources: <ul style="list-style-type: none">• Configurable 1 - 60 Hz output pulse
Lidar Operating Modes	Hardware-triggered angle firing (guaranteed fixed resolution per rotation): <ul style="list-style-type: none">• x 512 @ 10 Hz or 20 Hz• x 1024 @ 10 Hz or 20 Hz• x 2048 @ 10 Hz
Additional Programmability	Multi-sensor Phase Lock Azimuth Masking Low-power Standby Mode Queryable intrinsic calibration information: <ul style="list-style-type: none">• Beam angles• IMU pose correction matrix

MECHANICAL/ELECTRICAL

Power Consumption	14 - 20 W (23 W peak at startup, 28 W peak if operating below -40 °C)
Operating Voltage	9V - 34 V, 12 V or 24 V nominal
Connector	Proprietary pluggable connector (Power + data + DIO)
Dimensions	Diameter: 85 mm (3.34 in) Height: <ul style="list-style-type: none">• Without cap: 58.35 mm (2.3 in)• With thermal cap: 73.5 mm (2.9 in)
Weight	Without cap: 377 g (13.3 oz) With radial cap: 447 g (15.8 oz)
Mounting	Bottom: 4x M3 screws, 2x locating 2 mm pin holes Top: 4x M3 screws, 4x locating 2 mm pin holes, 1x M6 screw

OPERATIONAL

Operating Temperature	-40 °C to +60 °C (with mount) Between +53 °C and +60 °C, sensor automatically reduces range (max 20% range reduction)
Storage Temperature	-40 °C to +75 °C
Ingress Protection	IP68 (1m submersion for 1 hour, with I/O cable attached) IP69K (with I/O cable attached)
Shock	IEC 60068-2-27 (Amplitude: 100 g, Shape: 11 ms half-sine, 3 shocks x 6 directions)
Vibration	IEC 60068-2-64 (Amplitude: 3 G-rms, Shape: 10 - 1000 Hz, Mounting: sprung masses, 3 axes w/ 8 hr duration each)
Compliance	<p>For US</p> <p>Laser Safety:</p> <ul style="list-style-type: none">• IEC/EN 60825-1:2014 Class 1 eye safe• FDA US 21CFR 1040 Laser Notice 56 <p>Product Safety:</p> <ul style="list-style-type: none">• UL 62368-1• CSA 22.2 No. 62368-1-19 <p>EMC: FCC 47CFR Part 15, Subpart B, Class A</p> <p>For EU</p> <p>Laser Safety: IEC/EN 60825-1:2014 Class 1 eye safe</p> <p>Product Safety: EN/IEC 62368-1</p> <p>EMC:</p> <ul style="list-style-type: none">• EN 55032:2012/AC 2013; CISPR 32:2015• EN 55024:2010; CISPR 24:2010• EN 61000-3-2:2014• EN 61000-3-3:2013 <p></p>

ACCESSORIES

Included Interface Box	Polycarb/FR4, 100 g, 75 mm x 50 mm x 25 mm (LxWxH), 2 m CAT6 cable, 24 V power adapter, 5 m sensor cable
Optional Mount	Aluminum, 530 g, 110 mm x 110 mm x 20.5 mm (LxWxH), 4 x M8 thru holes

SOFTWARE

Sample Drivers	ROS, C++, Python
----------------	------------------

EXTERIOR DIMENSIONS

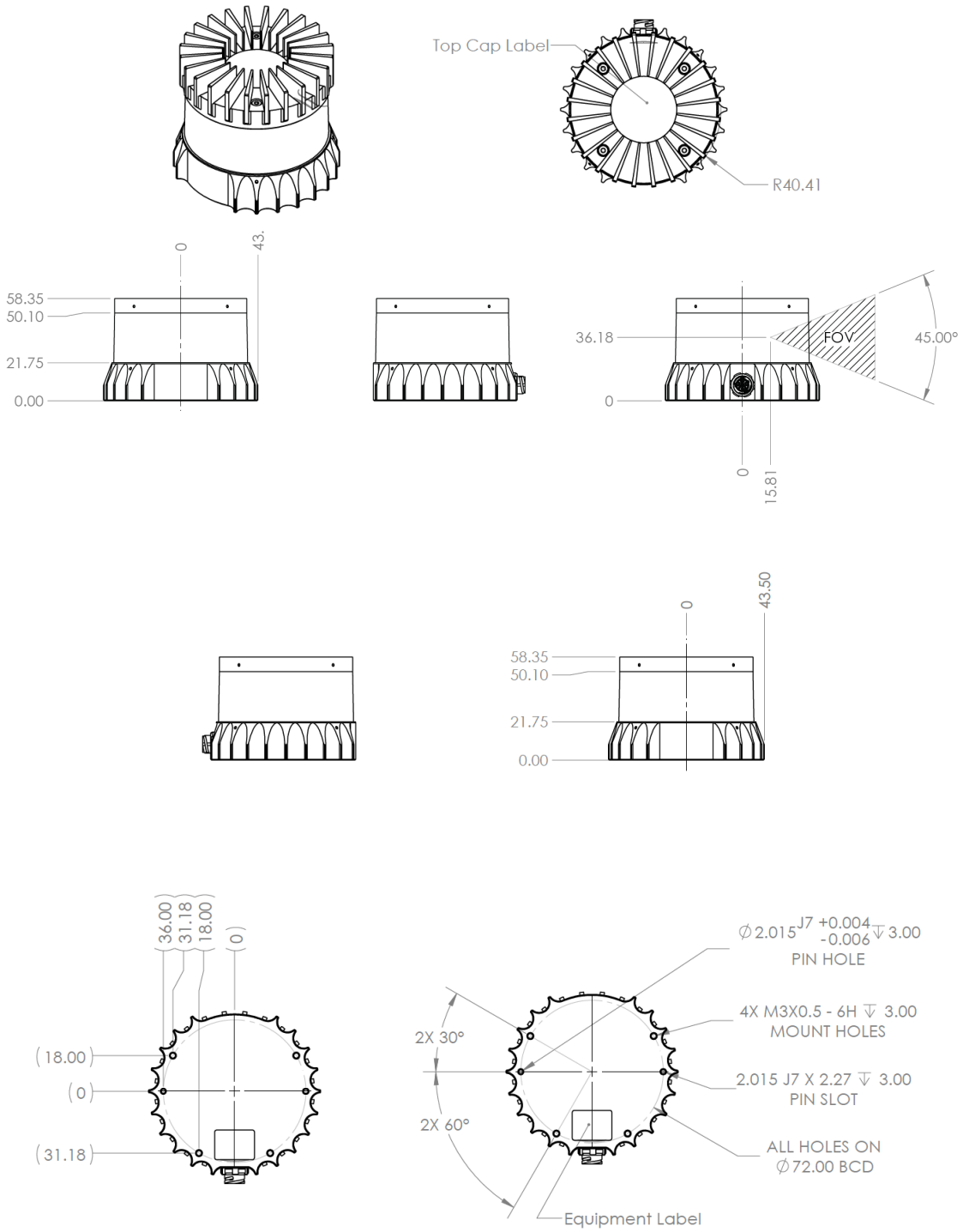

2X \varnothing 2.015 J7 $\begin{matrix} +0.004 \\ -0.006 \end{matrix}$ ∇ 3.50
PIN HOLE

4X M3X0.5 - 6H ∇ 4.00
MOUNT HOLES

M6X1.0 - 6H ∇ 6.00
MOUNT HOLES

2X 2.015 J7 X 3.00 ∇ 3.50
PIN SLOT

ALL HOLES ON
 \varnothing 60.00 BCD

8X 45°

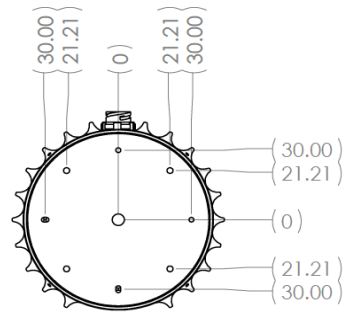

*Specifications are subject to change without notice and based on engineering targets. Specs are not guaranteed to have passed full validation at the time of publication.

WWW.OUSTER.COM

REV: 04/20/22 • © 2022 Ouster, Inc. • All rights reserved